

WOODBURNING STOVE AND FURNACE QUESTIONNAIRE

Please answer all questions fully. Submit this Questionnaire with a **completed** ACORD Commercial Insurance Applicant Information Section and prior carrier loss runs.

Named Insured: _____

PROHIBITED CIRCUMSTANCES

If any of the questions in this section are answered "YES", you are not eligible for coverage.

- | | | |
|---|------------------------------|-----------------------------|
| 1. Do you have a homemade or barrel type stove/furnace? | <input type="checkbox"/> Yes | <input type="checkbox"/> No |
| 2. Is your stove/furnace the primary source of heat? | <input type="checkbox"/> Yes | <input type="checkbox"/> No |
| 3. Do you have fireplace inserts or a freestanding fireplace? | <input type="checkbox"/> Yes | <input type="checkbox"/> No |
| 4. Is your stove/furnace sharing a flue with other heating devices? | <input type="checkbox"/> Yes | <input type="checkbox"/> No |

STOVE/FURNACE INFORMATION

1. Stove/furnace manufacturer: _____
2. Is the stove/furnace UL listed? Yes No
 - a. Is the exhaust handling equipment UL listed? Yes No
3. Who installed the stove/furnace: _____
4. What type of floor protection surrounds the stove/furnace: _____
5. How often is the stove/furnace cleaned? _____
6. How many woodburning devices are there: _____
 (Complete a separate report on each)
7. Chimney:
 - a. Is the stove/furnace connected to the same flue as other heating devices? Yes No
 If yes, list other device(s) and type of flue: _____
 - b. Is the chimney constructed with masonry Yes No
 If yes, is there a tile flue lining from below the stovepipe entry point to the top of the chimney? Yes No
 - c. If the chimney is non-masonry, is it a Class A all-fuel UL listed metal chimney? Yes No
 - d. If neither b nor c applies, describe (for example, is an ordinary single wall stovepipe being used as a chimney?) _____
8. Basic construction of room with woodburning stove:
 - a. The wall(s) in the area of the stove is (are):

<input type="checkbox"/> Plaster or drywall over wood studs.
<input type="checkbox"/> Cement block or solid stone, brick or concrete.
<input type="checkbox"/> Other: _____
 - b. The covering(s) on the wall is (are):

<input type="checkbox"/> Wood paneling
<input type="checkbox"/> Wallpaper
<input type="checkbox"/> Paint
<input type="checkbox"/> Other: _____
 - c. The floor is:

<input type="checkbox"/> Wood
<input type="checkbox"/> Cement
<input type="checkbox"/> Other: _____

9. Fire extinguisher:

- a. Is there a fire extinguisher on the premises?
- b. Is the fire extinguisher in operating condition?
- c. Is there a smoke detector?
- d. Is there a heat sensor?

<input type="checkbox"/> Yes	<input type="checkbox"/> No
<input type="checkbox"/> Yes	<input type="checkbox"/> No
<input type="checkbox"/> Yes	<input type="checkbox"/> No
<input type="checkbox"/> Yes	<input type="checkbox"/> No

COMPLETE THIS SECTION FOR STOVES, COOKSTOVES OR UNITS LISTED AS OTHER

- 1. Side of unit nearest wall: _____ inches.
- 2. Rear of unit to wall: _____ inches.
- 3. Bottom of unit to floor: _____ inches.
- 4. Top of smokepipe to ceiling: _____ inches.
- 5. Smokepipe to nearest wall: _____ inches.
- 6. Front of unit to front edge of floor protection: _____ inches.
- 7. Number of elbows: _____
- 8. Is stove secure? Yes No
- 9. Outside air intake? Yes No

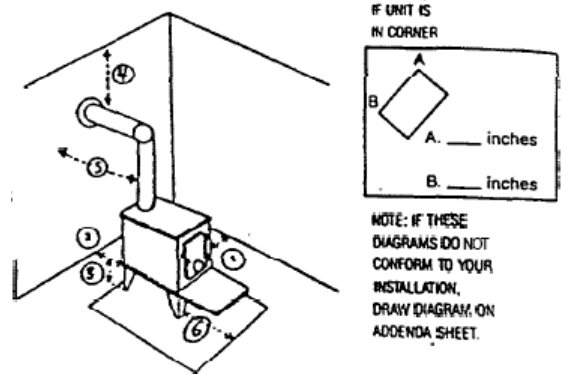

COMPLETE THIS SECTION FOR ADD ON AND CENTRAL UNITS

- 1. Side of unit nearest wall: _____ inches.
- 2. Rear of unit to wall: _____ inches.
- 3. Bottom of unit to floor: _____ inches.
- 4. Top of smokepipe to ceiling: _____ inches.
- 5. Top of hot air plenum to ceiling: _____ inches.
- 6. Top of air duct within 3' to ceiling: _____ inches.
- 7. Top of air duct 3' to 6' to ceiling: _____ inches.
- 8. Top of air duct 3' to ceiling: _____ inches.
- 9. Distance between add-on and furnace: _____ inches.
- 10. Does the add-on have a blower? Yes No

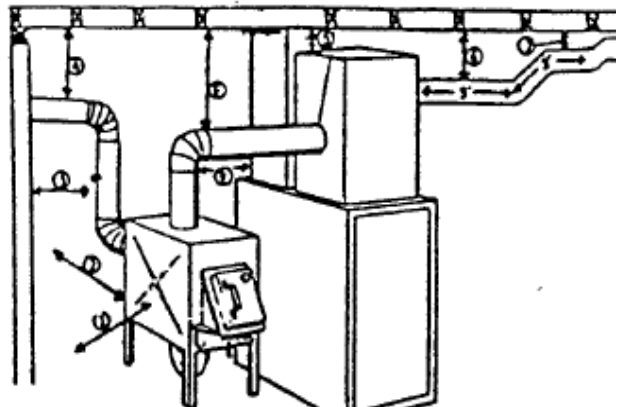

If yes, is the blower connected to cold air return? Yes No

COMPLETE THIS SECTION FOR WALL/CEILING PASSTHROUGH

- 1. Type of wall/ceiling pass through:

<input type="checkbox"/> Fire clay thimble	<input type="checkbox"/> Insulated metal pipe	<input type="checkbox"/> Other _____
<input type="checkbox"/> Stove pipe	<input type="checkbox"/> Listed wall pass through	
- 2. Distance from wall pass through to combustible (if visible): _____ inches Not visible



Capitol Indemnity Corporation
 Capitol Specialty Insurance Corporation
 Platte River Insurance Company

IMPORTANT NOTICE

I DECLARE THAT THE STATEMENTS MADE IN THIS APPLICATION ARE COMPLETE AND TRUE TO THE BEST OF MY KNOWLEDGE AFTER REASONABLE INQUIRY.

Any person who knowingly and with intent to defraud any insurance company or another person submits an application for insurance or statement of claim containing any materially false information, or conceals for the purpose of misleading, information containing any material fact thereto, commits a fraudulent act that is subject to criminal and substantial civil penalties. **I agree that any intentional concealment or misrepresentation of a material fact concerning this insurance or the subject thereof may void any policy issued.**

(As part of our underwriting procedures, a routine inquiry may be made to obtain applicable information concerning character, general reputation, and credit history. Upon your written request, additional information as to the nature and scope of the report, if one is made, will be provided.)

Applicant Signature	Title	Date
---------------------	-------	------

Producer Signature	Date
--------------------	------

Producer Name and Address